

# Stackable Slatted Wood Shoe Rack

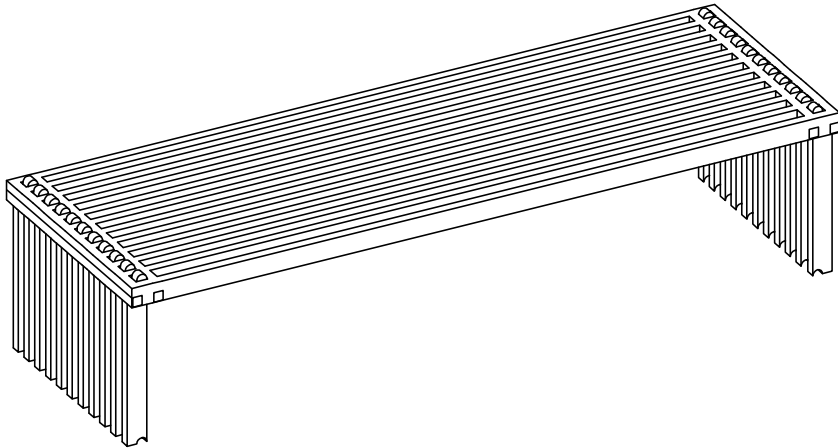

**Parts:**

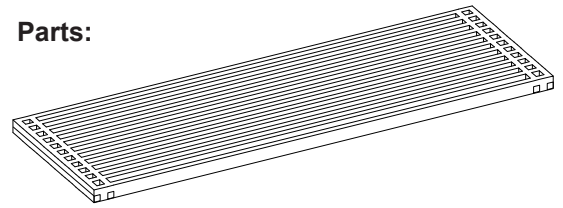

**A** 1 ea  
Top Frame

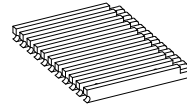

**B** 2 ea  
Side Frames

**Wear gloves or handle with a towel to avoid splinters. A rubber mallet may be used to ease assembly.**

**STEP 1:** Start the assembly upside down. Follow the drawing below to align the tabs on the side frames (**B**) with the holes on the top frame (**A**). Wiggle the side frames (**B**) to ease the tabs into the holes on the top frame (**A**) until half way inserted.  
**NOTE:** it can be a tight fit. Side frames are designed to fit tightly for stability and require a firm push for proper assembly.

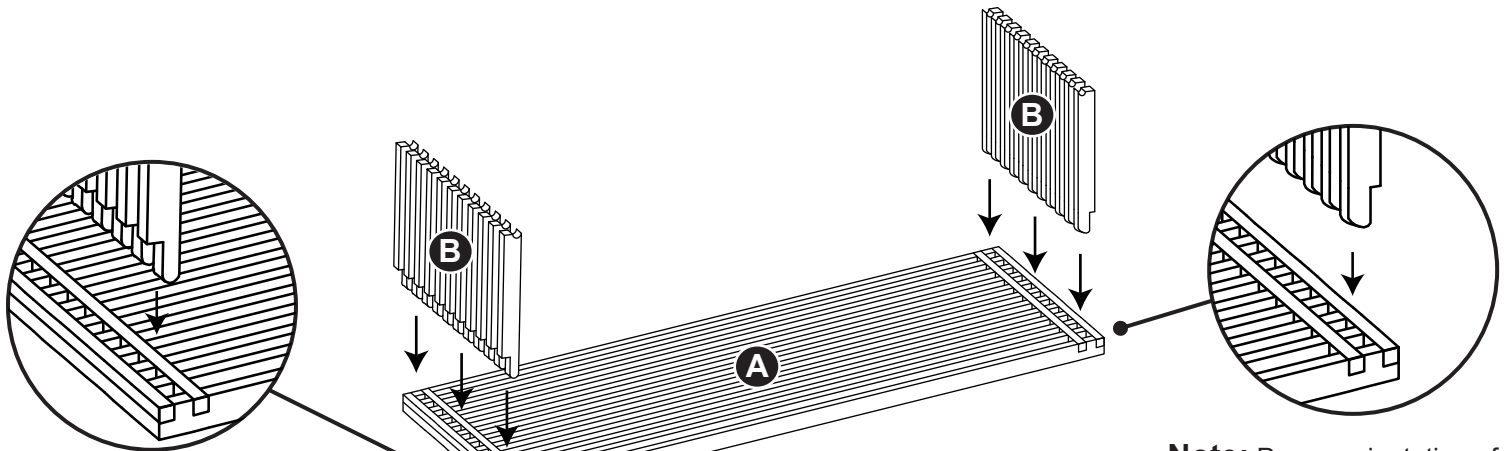

**Note:** Proper orientation of the top frame crossbar as well as the side frame tabs.

**Note:** Proper orientation of the top frame crossbar as well as the side frame tabs.

**STEP 2:** Flip the rack right side up. Push onto the top frame (**A**) until fully inserted. If available, use a rubber mallet (not included) and **gently tap** on the top frame (**A**) near the side frames to ease assembly.

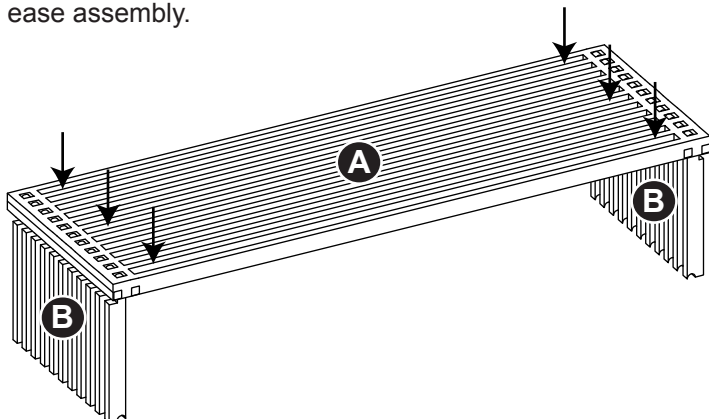

**Multiple units may be stacked:** Please use an anti-tip kit (not included) if height exceeds 36 inches.

